

MANUALE DI USO E MANUTENZIONE
OPERATING AND MAINTENANCE MANUAL
MANUEL D'USAGE ET DE ENTRETIENE
BEDIENUNGSANLEITUNG UND WARTUNG
MANUAL DE EMPLEO Y MANUTENCIÓN

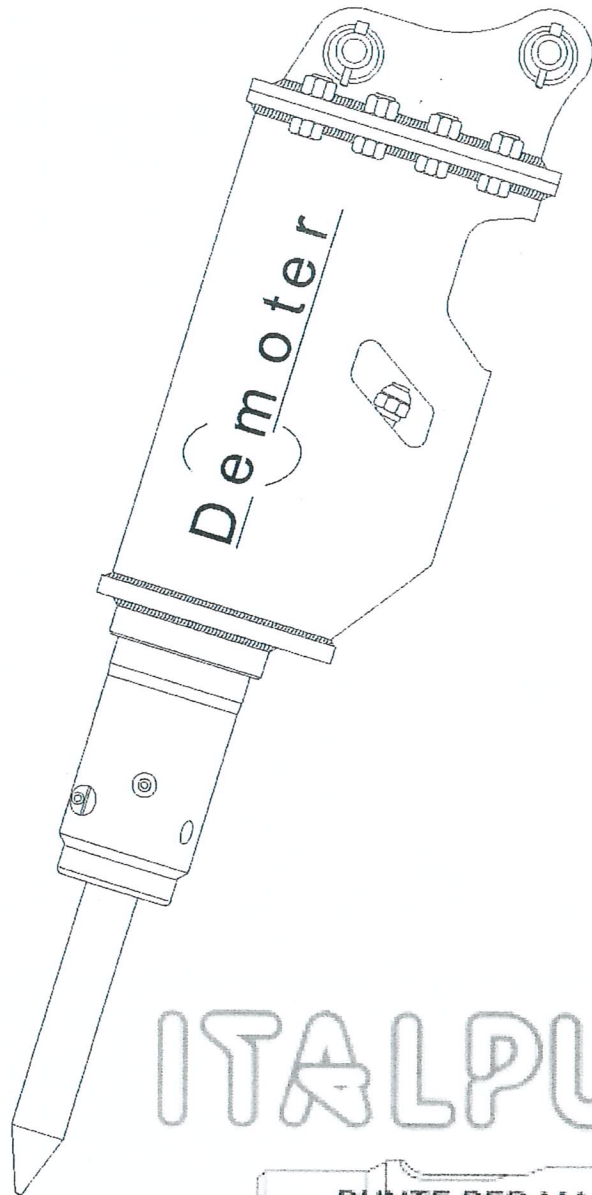

**DEMOTER
S 1000**

ITALPUNTE[®]  **SRL**

PUNTE PER MARTELLI DEMOLITORI

Sede e Magazzino
Via San Maurizio, 23 - 10072 Caselle (TO) Italy
Tel. +39.011.9914190 - Fax +39.011.9914476
www.italpunte.com - info@italpunte.com

THANK YOU FOR CHOOSING OUR PRODUCT

All information, recommendations and instructions that our technicians have considered relevant for the correct use of the hydraulic breaker have been included in this manual.

It also includes the rules for regular servicing, which will enable you to keep the hydraulic breaker perfectly efficient.

We recommend you also to read all its parts before attempting the use of the hammer for the first time.

WARRANTY NOTES:

ITALPUNTE SRL gives no warranty on wearing parts, especially the following:

- Seals and Diaphragms
- Tie Rod bolts
- Retaining Pins
- Tools

Index

1. General and Safety Information	page.	4
2. Usage Notes and Safety Instructions	page.	5
3. Protection Devices for Safety	page.	6
4. Personal Protection Equipment	page.	6
5. Hydraulic Breaker Technical Specifications	page.	7
5.1. Tightening Torques for screw connections	page.	7
5.2. Chuck Housing and Tool wear monitoring	page.	8
5.3. Operating Pressures	page.	8
6. Hydraulic Connection to Excavator	page.	9
7. Required Operations and Checks	page.	10
7.1. Inspections	page.	10
7.2. Tool Removal	page.	11
8. Strokes Frequency Adjustment	page.	12
9. Noise Level	page.	12
10. Servicing	page.	13
11. Overall Dimensions	page.	14
12. Correct Use	page.	15-16
13. Types of Tools	page.	17
14. Solutions to Key Problems	page.	18
15. Spare Parts (Breakers' Exploded Diagram)	page.	19
16. Parts List and Codes	page.	20-21
Warranty Certificate	page.	22

1. GENERAL SAFETY INFORMATION

RECOMMENDATIONS FOR USE AND MAINTENANCE

For this manual draft we considered all those operations falling within the usual practice. Keep this manual in good condition and keep it always available near the breaker or in near by place. We urge you not execute any processing, repair or intervention not mentioned in this manual.

HAMMER IDENTIFICATION

The Hydraulic Breaker is identified by its CE plate placed at its side, close to the attachment pins to the excavator. In case of ordering spare parts, or requests for advice on the usage or maintenance, always refer to the type of breaker and Serial Number indicated in the CE plate. It is absolutely forbidden to remove it or to modify the features contained therein. As shown below, the CE plate is applied on **ITALPUNTE** Hydraulic Breakers to which this manual refers.



2. USAGE NOTES AND SAFETY INSTRUCTIONS

A close and a careful following of all the instructions in this manual will allow a safe and correct use of the hammer.

The hammer shall be used only by persons older than 18 years who has been adequately trained to use it.

It is necessary that the responsible for corporate security makes sure that the staff designed to use the hammer has read and understood this manual in all of its parts. Adjustment and maintenance servicing must also be performed by authorized, trained and over the age of 18 years personnel.

It is recommended that those who use this publication for maintenance and repairing must have a basic knowledge of the principles of mechanics and procedures concerning the technique of repairing.

Connect the Hydraulic Breaker only to an excavator with appropriate weight.
Do not touch any part while arms are moving.

Make sure that the relief valve of the excavator's hydraulic system is set at 40 bar higher than the working pressure of the breaker specified at page 7.

Every manipulation or removal of security elements can lead to serious accidents.
Keep hands away from holes and joints when connecting the breaker to
Excavator.

3. PROTECTION DEVICES FOR SAFETY

A set of plates is placed on the back of the hydraulic breaker to draw operator's attention. See figures

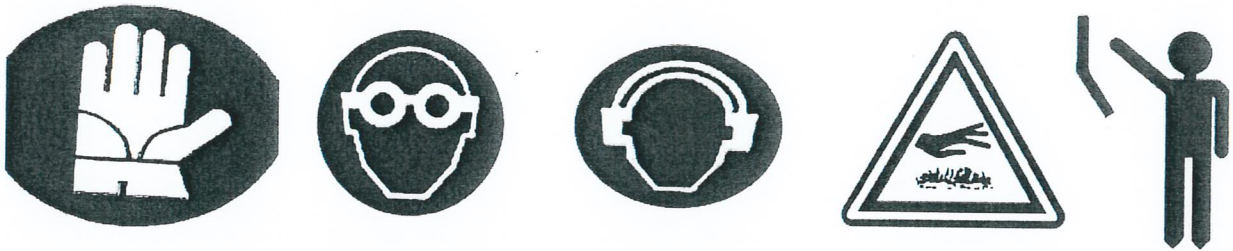

4. PERSONAL PROTECTION EQUIPMENT

Always wear safety goggles during the assembly and dismantling of the tool.



Wear protective gloves before removing the centering pins.



Use a head set for hearing protection if the noise level exceeds 90 db



Beware of the burning parts since the breaker can reach high temperatures when operating.



Close the windshield or the protection of the command cabin to protect from rock's splinters.



5. HYDRAULIC BREAKER TECHNICAL SPECIFICATIONS

WEIGHT	KG	1050
HEIGHT WITH STANDARD TOOL	mm	2050
TOOL DIAMETER	mm	115
STANDARD TOOL LENGTH	mm	1000
REQUIRED OIL FLOW	L/Min	100÷145
BLOWS PER MINUTE	B/Min	450÷750
HAMMER OPERATING PRESSURE	bar	110÷170
BLOW IMPACT ENERGY	joule	3000
CARRIER WEIGHT	ton	12÷25
INTERNAL DIAMETER OF THE FEEDPIPE	mm	3/4
INTERNAL DIAMETER OF THE RETURN PIPE	mm	3/4
MAXIMUM PERMITTED RETURN PRESSURE	bar	25

5.1 TIGHTENING TORQUES FOR SCREW CONNECTIONS

CODE	DESCRIPTION	TORQUE Kgm
L000061	Tie Rod	50
L000055	Backhead Bolt	15
L000057	Top Bracket Bolt	25

5.2 CHUCK HOUSING AND TOOL WEAR MONITORING

ORIGINAL TOOL DIAMETER	mm	114
MINIMUM REQUIRED TOOL DIAMETER	mm	111
ORIGINAL CHUCK HOUSING DIAMETER	mm	115
MAXIMUM ACCEPTABLE CHUCK HOUSING DIAMETER	mm	118,5

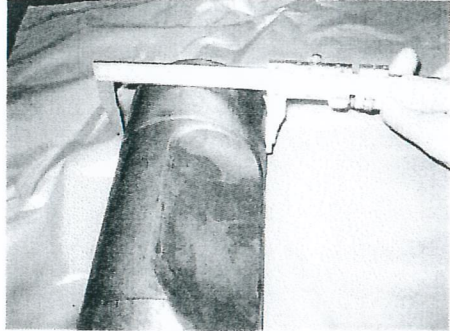
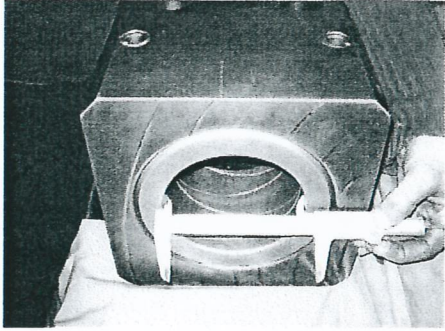

5.3 OPERATING PRESSURES

OIL

FLOW	PRESSURE
135 LIT./MIN	170 bar

LOW PRESSURE: (IN THE BACKHEAD) 8 bar
 Use Nitrogen (N₂) with 99,8% degree of purity

Instructions for charging:

- A) Unscrew completely the ¼" GAS cap by a 6mm hex key
- B) Connect the nitrogen cylinder pipe by a ¼" GAS nipples
- C) Charge nitrogen at a 8 bar pressure at 20°C
- D) Leave charging for a few minutes
- E) Unscrew the pipe and nipples, refit the cap

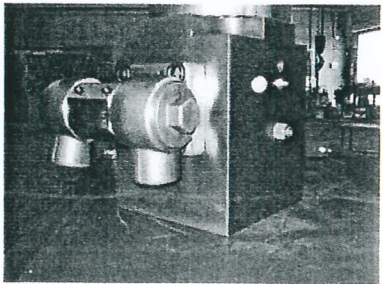
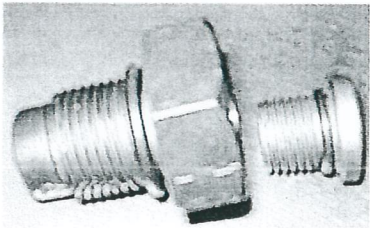

To completely discharge nitrogen from the head, unscrew the valve cap and push the sphere inside by a pointed tool

6. HYDRAULIC CONNECTION TO EXCAVATOR

The hydraulic connection of the breaker to excavator is made by rubber hoses. Such hoses are connected by one end to excavator using taps or quick couplings with 1" GAS for IN and OUT oil flow and by the other end to the hydraulic breaker with a 1" GAS thread both for "IN" and "OUT"

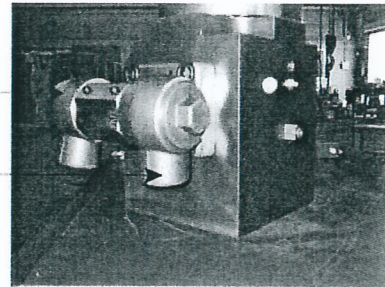
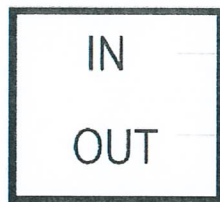

The hose is connected to the breaker using nipples 1"GAS M-M. The delivery flow joint is indicated by an "IN" inscription and the back flow joint is indicated by an "OUT" inscription. Such inscriptions are marked near the connecting joints. The S1000 breaker's delivery flow is right side and the back flow is left side. On all the models manufactured by us, there is a plate showing the CE marking in compliance with the manufacturing principles dictated by the European Norm 2000/14.

7. REQUIRED OPERATIONS AND CHECKS

Before mounting the tool, it is important to sprinkle the chuck bushing with molybdenum disulfide grease (MoS₂) recommended by us.

Before starting the hydraulic breaker, the tool should be brought into contact with the material to be broken then you need to apply pressure on the hammer with the excavator's arm so that the breaker is armed and ready to start.

The front of the excavator can be raised by a few centimeters from the round so that its weight rests completely on the tool.

Before engaging the starting device of the breaker, close the windshield or the splinterguard of the command cabin. This allows you to protect against rock fragments that can be blown during the functioning of the breaker.

Ensure that the staff outside the cabin of the excavator is distant at least 20m from working area.

7.1 INSPECTIONS

- Monitoring of screw connections in the breaker subject to stress caused by its vibrations.
- Retaining Pin Integrity Checking.
- Rubber Hoses Checking.
- Checking of any possible oil leakage along the tool.
- Tie Rods Integrity Checking.
- Checking of loose angle of the tool in its housing.
- Tool wear Checking. In case that it is worn beyond the permitted limits, it must be replaced.
- Checking of the diameter of the wear bushings, where provided, according to the allowed diameters.
- Checking of the integrity of the housing.

7.2 TOOL REMOVAL

Follow these steps to remove the tool: remove the pin (A) from its housing with a pin punch and a hammer.

Then push the retaining pin (B) from the opposite side and remove the tool (C).

Follow these steps to place the tool: after greasing the chuck bushing with bisulfure of molybden grease insert the tool, then insert the two retaining pins in thier location and lock them with the same pins previously kept off.

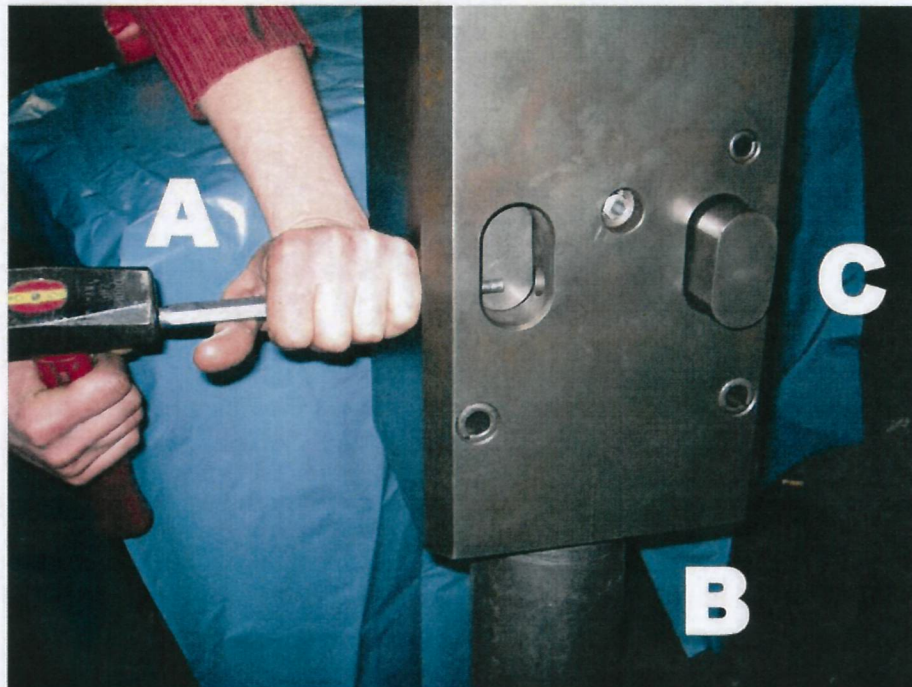

8. STROKES FREQUENCY ADJUSTMENT (picture at page 14)

Adjust the amount of oil we have recommended (25 to 30 lit/min) using a flow meter and the excavator's accelerator or some valve fitted on it.

If there is no flow meter, while the excavator is started, using a pressure gauge mounted on its supply line, reach more or less the pressure recommended by us (100bar) by accelerating or adjusting the oil pressure valve of the excavator (if any).

WARNING: check that the relief valve of the excavator's hydraulic system is always set at least 30 bar higher than the recommended pressure.

9. NOISE LEVEL (Accordingg to the Directive 2000/14)

According to the surveys of the sound level measurements, Hydraulic Breaker's noisiness results to be:

LWA measurement:

db(A) 125

LWA secured:

db(A) 128

10. SERVICING

- Lubricate the tool regularly once every two hours with 2 or 3 pumpings of the greaser (only if there is not the automatic greasing unit on the excavator).
- Inspect the tool every 50 hours (7.2 pag. 11).
- Check that both the diameters of the tool and of the chuck housing correspond to those previously indicated (page 8)
- Make sure that on the surface of the retaining pins there are no bulges that may affect the outgoing of the tool from the breaker. Should this occur, remove the exceeding material by grinding.
- Check the bolt tightening during the first 50 working hours. After this period a monthly monitoring is sufficient.
- Use nitrogen gas (N) with 99,8% purity.
- Before removing the breaker's back head, make sure that the nitrogen pressure (page 8) has been completely drained away through the nitrogen valve which is under the oil feeding holes on the back head.

11. OVERALL DIMENSIONS

See the dimensions shown in the drawing

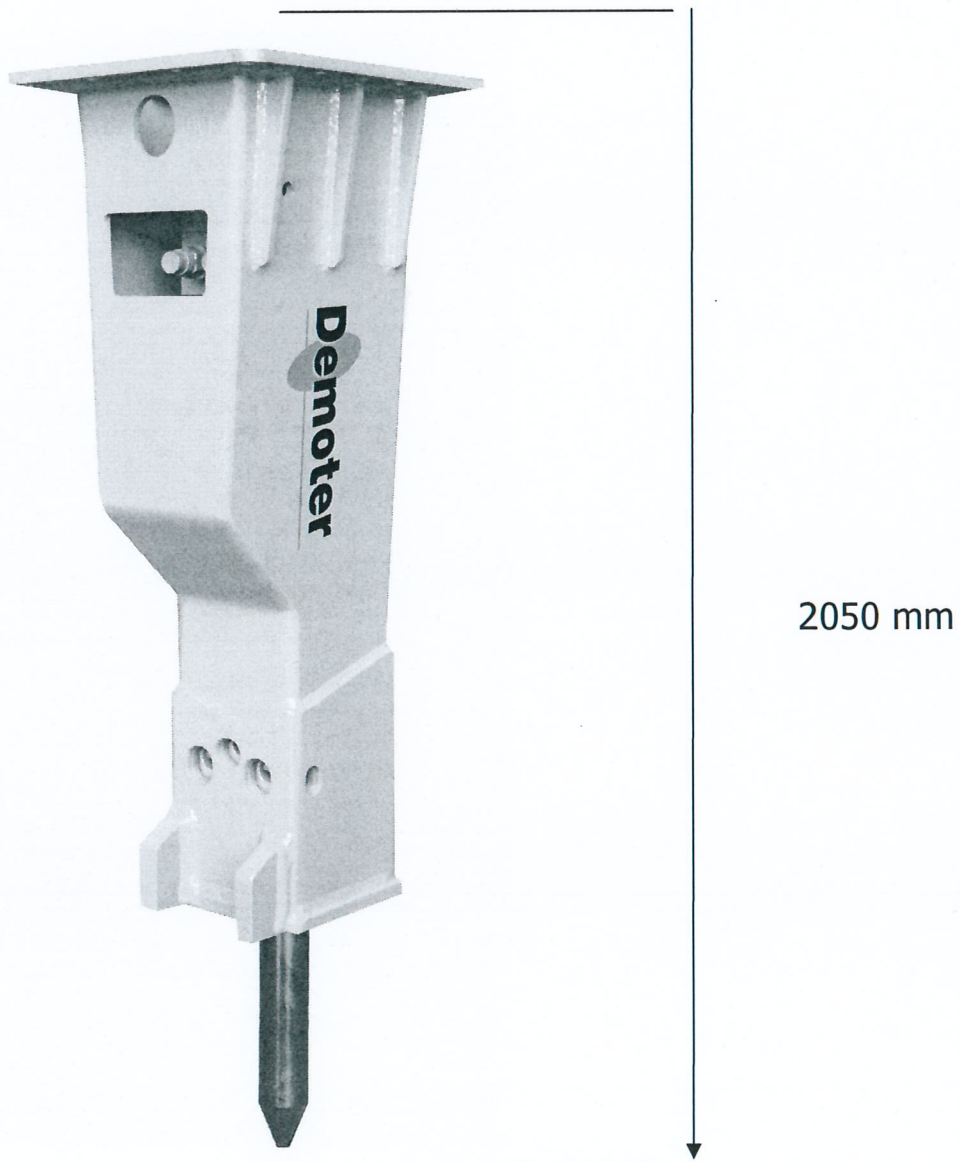

12. CORRECT USE

Engage the Block. Avoid to rest on a surface which can make your breaker slide while engaging the block. If this happens, there may be damaging shocks to both the excavator and breaker.

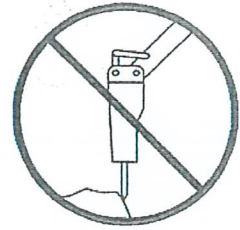

Blank Firing. Special care has to be taken not to carry out blank firing. A blank firing may cause Tie Rods' breaking. These are parts which keep together the various components of the breaker. Furthermore it may cause Retaining Pins' and Tools' breaking. Thus you have to disconnect the power supply to hammer at the exact moment of rock breaking.

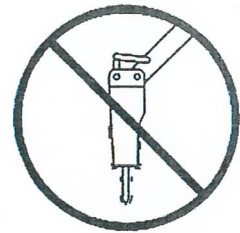

Correct Position. The breaker can work at any angle. However it is important that the boost is always given along the axis of the tool of the breaker.

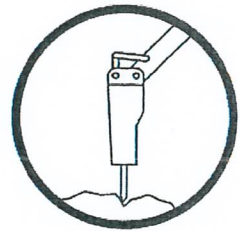

The correct pressure (A). An insufficient pressure would cause vibrations to the machine and breaker's energy would not be completely released on the boulder.

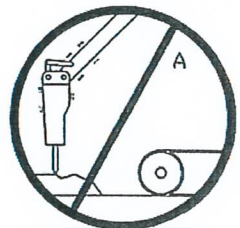

The correct pressure (B). With an excessive pressure, resulting in jacking up the tracks or the wheels, the machine would fall forwards when rock breaks with damaging consequences for itself and for the breaker.

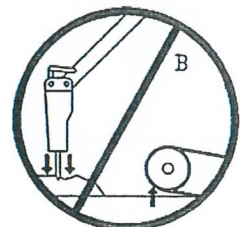

12. CORRECT USE

Engage the Block. Avoid to rest on a surface which can make your breaker slide while engaging the block. If this happens, there may be damaging shocks to both the excavator and breaker.

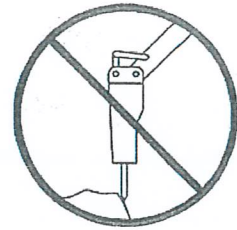

Blank Firing. Special care has to be taken not to carry out blank firing. A blank firing may cause Tie Rods' breaking. These are parts which keep together the various components of the breaker. Furthermore it may cause Retaining Pins' and Tools' breaking. Thus you have to disconnect the power supply to hammer at the exact moment of rock breaking.

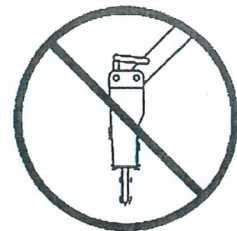

Correct Position. The breaker can work at any angle. However it is important that the boost is always given along the axis of the tool of the breaker.

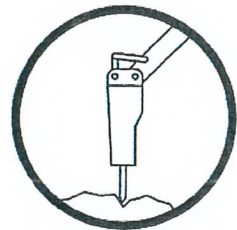

The correct pressure (A). An insufficient pressure would cause vibrations to the machine and breaker's energy would not be completely released on the boulder.

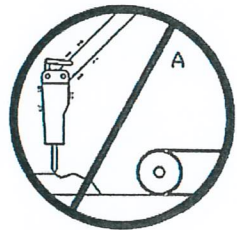

The correct pressure (B). With an excessive pressure, resulting in jacking up the tracks or the wheels, the machine would fall forwards when rock breaks with damaging consequences for itself and for the breaker.

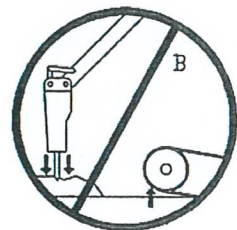

13. TYPES OF TOOLS

Chisel Tool. This tool is suitable for all kind of earth moving or narrow section excavations on all types of rock.

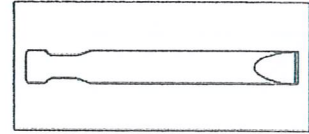

Blunt Tool. This tool is suitable for boulder's breaking or for various reinforced concrete demolitions

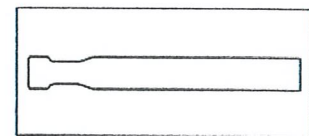

Moil Point Tool. Suitable for all reinforced concrete structure demolition. It is also suitable for medium hardness

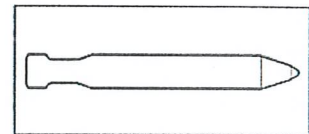

Asphalt Cutter or Spade Tool. Available as parallel asphalt cutter (B) suitable for roadworks. As transversal cutter (A) suitable for wood or compact frozen soil.

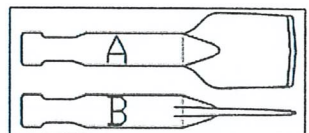

14. SOLUTIONS TO KEY PROBLEMS

HERE BELOW IS A LIST OF THE MAIN PROBLEMS THAT COULD OCCUR DURING THE BREAKER'S OPERATION WITH THEIR CAUSES' IDENTIFICATION AND REMEDIES TO BE CARRIED OUT.

PROBLEM	CAUSE	SOLUTION	EXECUTION
THE BREAKER DOES NOT START	Blocked Tool	Remove and replace the tool	Operator Workshop
	Defect in the Rubber Hoses with quick couplings (no oil flow)	Check the hoses, repair or replace couplings	Operator
	Defect in the control valve of the excavator's hammer plant	Check that the relief of hammer's plant reacts after 200 bar	Workshop
	Hydraulic oil is low in excavator's tank	Restore the oil level	Operator
	Breaker's failure	Disassemble the breaker and check it	Workshop
LACK OF STROKE POWER			
	Low nitrogen pressure in the back head (unloaded)	Check and restore the pressure in the back head	Operator
	Nitrogen accumulator high pressure (unloaded)	Check accumulator's diaphragm	Workshop
	Low hydraulic oil flow	Restore the proper oil flow, check the working pressure	Workshop
	High oil temperature in the tank	Check the oil level in the tank and the cooling circuit	Operator
	Low oil pressure	Check that the setting of the relief valve of the breaker is at least 200 bar	Workshop
LOW SPEED WITH HIGH ENERGY STROKE			
	Tool locked in the chuck housing	Try to slide out the tool	Operator
	Breaker partly blocked	Piston or other dynamic element partly damaged	Workshop
LOSS OF OIL FROM THE TOOL	Worn cylinder seals	Dismount the breaker and replace all gaskets	Workshop
LOSS OF OIL FROM BP-HP CONNECTORS	Couplings not tightened	Tighten the connections	Workshop
LOSS OF OIL BETWEEN BACK HEAD AND CYLINDER	Side bolts not well tightened or broken	Tighten or replace the Tie-Rods	Workshop
TOO HIGH OPERATING TEMPERATURE	There is more oil arriving than expected	Reset the proper oil flow	Operator Workshop
	The atmospheric temperature is too high	Install an additional heat exchanger	Workshop
	Low oil level in excavator's tank	Restore oil level in the tank	Operator

15. SPARE PARTS (BREAKERS' EXPLODED DIAGRAM)

DEMOTER S1000

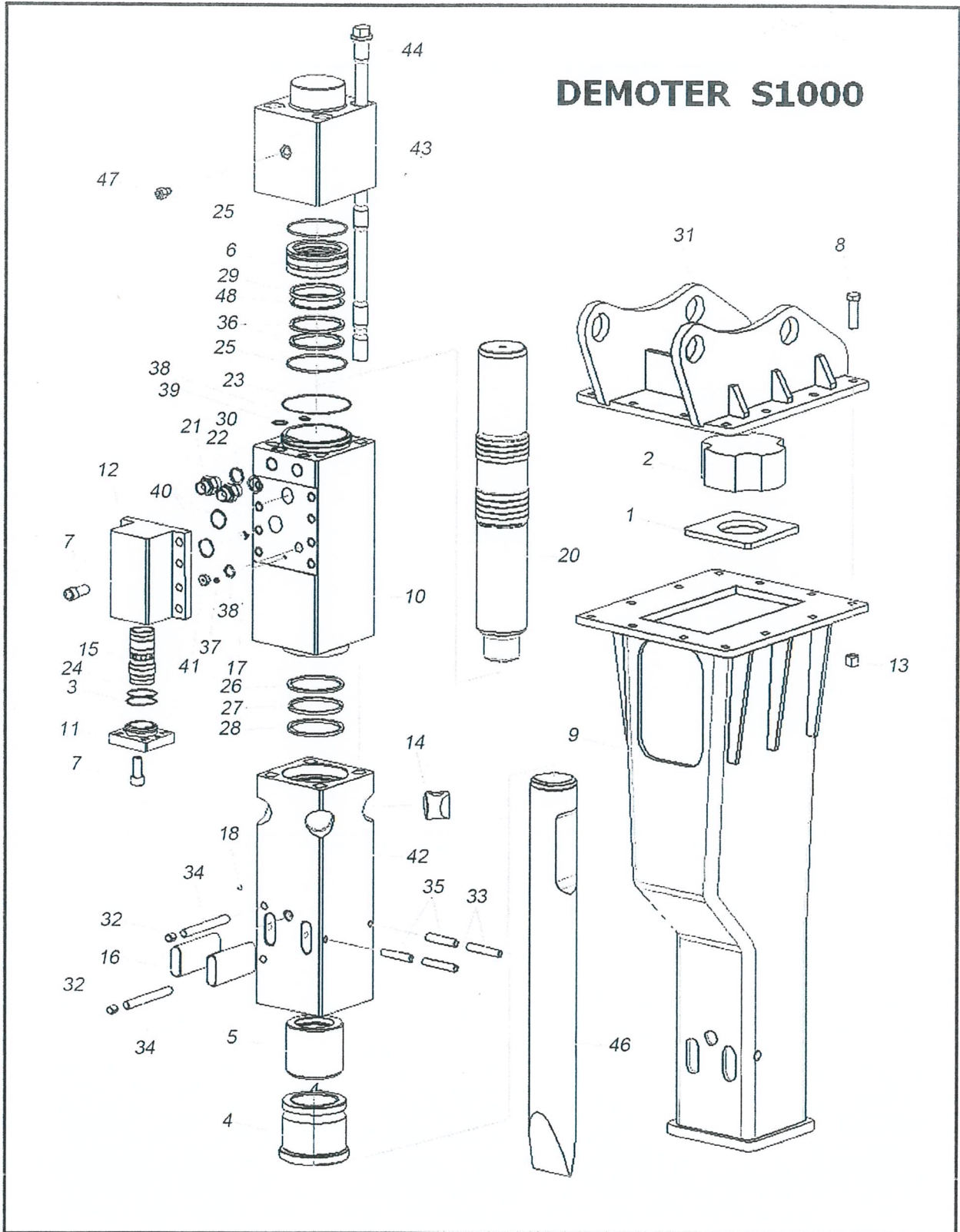

ITALPUNTE		DEMOTER S 1000		2014
ITEM	CODE	DESCRIPTION	Q.TY	
1	P100038	Ammortizzatore inferiore <i>Lower shock absorber</i>	1	
2	P100036	Ammortizzatore superiore <i>Upper shock absorber</i>	1	
3	C000165	Back-up coperchio distributore <i>Back-up distributor cover</i>	1	
4	P100007	Boccola porta utensile <i>Lower bushing</i>	1	
5	P100008	Boccola superiore <i>Upper bushing</i>	1	
6	P100011	Boccola porta guarnizioni <i>Cover bushing</i>	1	
7	C000012	Bullone corpo distributore <i>Distributor box bolt</i>	12	
8	C000380	Bullone sella <i>Mounting bracket bolt</i>	12	
9	C000719	Carcassa <i>Housing</i>	1	
10	P100002	Cilindro <i>Cylinder</i>	1	
11	P100014	Coperchio Distributore <i>Distributor cover</i>	1	
12	P100004	Corpo Distributore <i>Distributor box</i>	1	
13	C000478	Dado bullone sella <i>Nut for mounting bracket</i>	12	
14	P090016	Dado tirante <i>Nut for side bolt</i>	4	
15	P100012	Distributore <i>Distributor</i>	1	
16	P100020	Fermautensile <i>Retainer pin</i>	2	
17	C000002	Helicoil corpo distributore <i>Helicoil distributor</i>	8	
18	C000009	Ingrassatore <i>Grease nipple</i>	1	
19	P100021	Kit guarnizioni <i>Seal kit</i>	-	
20	P100010	Pistone <i>Piston</i>	1	
21	L000073	Nipple di mandata <i>Nipple "IN"</i>	1	
22	L000074	Nipple di ritorno <i>Nipple "OUT"</i>	1	
23	C000738	O.R. Cilindro <i>O-Ring back head (cylinder)</i>	1	
24	C000170	O.R. coperchio distributore <i>O-Ring distributor cover</i>	1	
25	C000739	O.R. portaguarnizioni <i>O-Ring for seal holder</i>	2	
26	C000063	Paraolio cilindro HBY <i>Lip seal HBY</i>	1	
27	C000062	Paraolio cilindro IDI <i>Lip seal IDI</i>	1	
28	C000061	Parapolvere <i>Dust seal</i>	1	

ITALPUNTE		DEMOTER S 1000		2014
ITEM	CODE	DESCRIPTION	Q.TY	
29	C000065	Quadring <i>Quadring</i>	1	
30	C000581	Guarnizione 1" Washer 1"	2	
31	H090091	Sella <i>Mounting bracket</i>	1	
32	C000350	Spina elastica boccia <i>Elastic pin for bushings</i>	2	
33	C000347	Spina elastica per fermautensile <i>Elastic pin for retainer pin</i>	2	
34	L000075	Spina cilindrica fermaboccola <i>Pin for bushing</i>	2	
35	L000076	Spina cilindrica fermautensile <i>Pin for retainer pin</i>	2	
36	C000059	Stepseal <i>Steapseal</i>	2	
37	C000221	Stirromatic <i>Stirromatic</i>	1	
38	C000073	Stirromatic <i>Stirromatic</i>	2	
39	C000121	Stirromatic <i>Stirromatic</i>	1	
40	C000189	Stirromatic <i>Stirromatic</i>	2	
41	L000071	Tappo corpo distributore <i>Distributor box plug</i>	1	
42	P100003	Testata inferiore <i>Chuck housing</i>	1	
43	P100001	Testata superiore <i>Back head</i>	1	
44	P100015	Tirante <i>Tie rod</i>	4	
45	H090019	Utensile a cono <i>Moil point</i>	-	
46	H090018	Utensile a scalpello <i>Chisel</i>	1	
47	C000042	Valvola azoto completa <i>Complete nitrogen valve</i>	1	
48	C000064	Back-up quadring <i>Back-up quadring</i>	1	

WARRANTY CERTIFICATE

The breaker is built in our factory according to technological and safety criteria and tested before shipping.

ITALPUNTE guarantees breaker's functioning and quality according to law provisions for a 12 months period. An improper use and a wrong maintenance which do not comply with the rules provided in this manual, as well as regulations or adjustments not approved by the manufacturer, void the warranty.

Warranty conditions about proper machine operation are related to compliance with all information provided in this manual.

The replacement of parts which will be proved to be defective will be done only after checking the proper use of the breaker. The recognition of the warranty is restricted only to the replacement of those parts recognized as defective. Under no circumstances, shipping or manpower expenses will be approved for the replacement of defective parts except for agreements with our management that would approve repairing in our factory only by charging the transportation costs of the breaker.

Complaints and requests for warranty service will be accepted only by submitting breaker's engraved number on the identification plate. At the moment you receive the breaker, check that the packing containing it is perfectly intact and has no damage. Unless otherwise agreed, the manufacturer is not responsible for damages caused during transportation. In the event that there is an evident damage on the packaging, you should immediately contact the transporter. Our company will be available to provide the necessary support.